

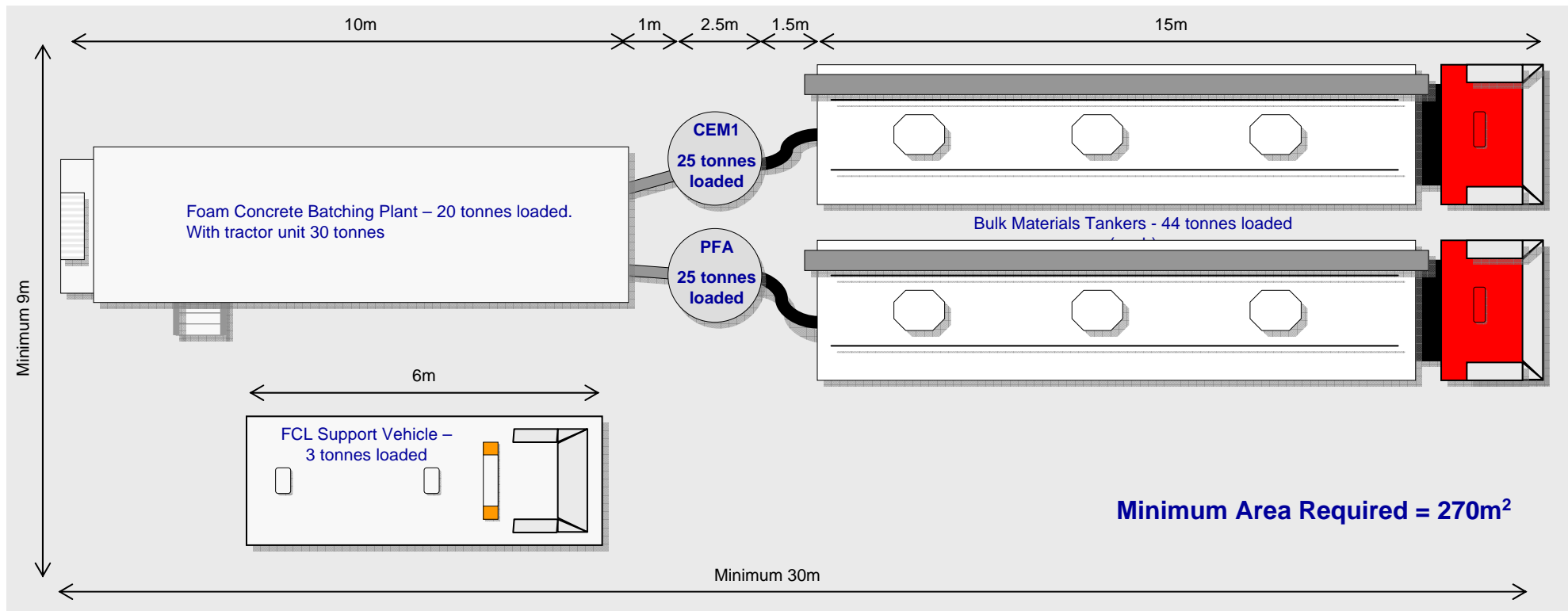

Foam Concrete Limited - Typical Site Footprint



What we need from you:

- Sufficient room for tractor unit to bring batching plant to site and place in position
- Secure, stable and level site to accommodate batching plant @ 20 tonnes and Silos @ 25 tonnes each
- Sufficient room to allow bulk materials tankers @ 44 tonnes each, to manoeuvre and discharge into silos
- Clean water supply via 50mm main

This illustration is not to scale and is for information only